

U.S. ARMY BANDS

Field Manual 12-50

(15 October 1999, supercedes FM 12-50, 6 September 1991)

Distribution Restriction: Approved for Public Release: distribution is unlimited

Appendix B

The Marching Band

SECTION II — MARCHING MOVEMENTS

B-12. This section describes the collective marching movements of Army bands. The movements covered are: Changing Posts, Left Turn, Right Turn, Alternate Left Turn, Alternate Right Turn, Reversible Countermarch, Nonreversible Countermarch, Guide Around and Half Turns, and Changing music.

CHANGE POSTS - DRUM MAJOR AT THE FRONT OF THE BAND

B-13. The band commander and drum major take the actions outlined in [Figure B-3](#) to exchange positions when the drum major is in front of the band. The band commander gives the command to change posts.

PREPARATORY COMMAND (CHANGE POST)

Band Commander

B-14. On the preparatory command Change Post, execute a Half-Left Face (alternate: no movement).

Drum Major

B-15. On the preparatory command Change Post, bring the mace to Carry. Execute a Left Face.

Command of Execution (March)

Band Commander

B-16. On the command of execution March, step-off (alternate: step off with a Half-Left Turn). March directly to the original position of the drum major. Halt and execute a Half-Right Face. You may wait and perform your final facing movement to coincide with the Drum Major's final facing movement.

Drum Major

B-17. On the command of execution March, march forward until you are two steps past the band's right flank. Execute a Right Turn and march until you are aligned with the front rank. Halt and do an About Face.

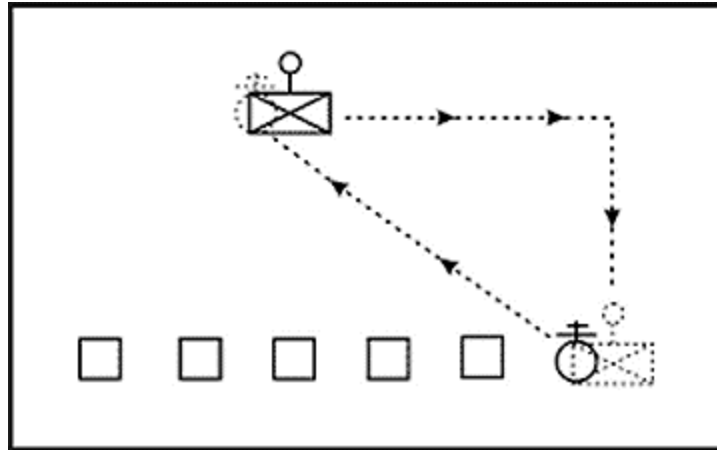

Figure B-3. Change Posts - Drum Major at the Front of the Band

CHANGE POSTS - BAND COMMANDER AT THE FRONT OF THE BAND

B-18. The band commander and drum major take the actions outlined in [Figure B-4](#) to exchange positions when the band commander is at the front of the band. The band commander faces the band and gives the command to change posts.

PREPARATORY COMMAND (CHANGE POST)

Band Commander

B-19. On the preparatory command "Change Post", execute a Half Left Face (alternate: no movement).

Drum Major

B-20. On the preparatory command "Change Post", bring the mace to Carry.

COMMAND OF EXECUTION (MARCH)

Band Commander

B-21. On the command of execution "March", step off (alternate: step off with a Half-Left Turn). March directly to the original position of the drum major. Halt and do a Half-Right Face. You may wait to do your final facing movement to coincide with the drum major's final facing movement.

Drum Major

B-22. On the command of execution "March", march forward until you are aligned with the original position of the band commander. Execute a Left Turn, and march forward until you are centered on the band. Halt and do a Right Face.

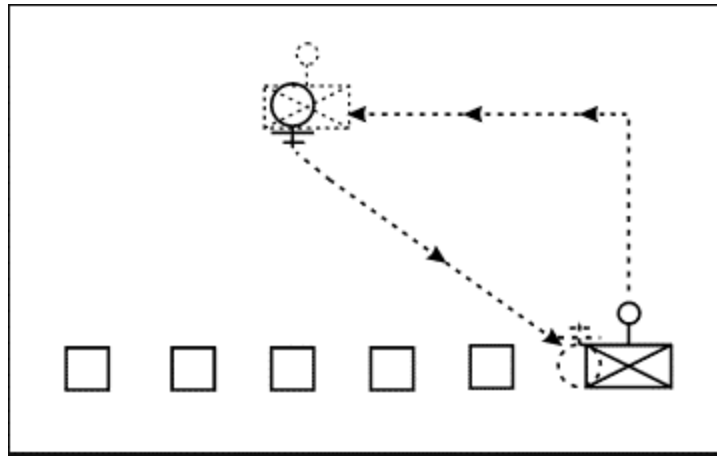

Figure B-4. Change Posts - Band Commander at the Front of the Band

LEFT TURN

B-23. [Figure B-5](#) illustrates the procedures for the band to execute a Left Turn.

DRUM MAJOR

B-24. Perform the Left Turn as it is described in the Manual of the Mace. When the first band member in the left file reaches the place to turn, perform the preparatory signal followed by the signal of execution. March forward until you are even with the first band member in the left file, then continue forward the appropriate number of steps and Mark Time. When all band members have turned and aligned themselves, signal a Forward March.

LEFT FILE

First Person in the File

B-25. If you are the first person in the file, take the following actions when the drum major performs the signal of execution: march one step and turn left. After the turn, march forward two steps for each rank in the band, then Mark Time. When the drum major signals Forward March, step off at a full step.

Other Members of the File

B-26. If you are not the first person in the file, turn left two steps after the person in front of you. Turn where the first file member turns. After the turn, march forward two steps for each rank in the band minus two steps for each rank in front of you: for example, if you are in the third rank of a band with seven ranks, march forward ten steps (14 minus 4). Mark Time. When the drum major signals Forward March, step off at a full step.

OTHER FILES

First Person in the File

B-27. If you are the first person in the file, take the following actions. Turn left two steps after the person to your left turns. March forward until you are aligned with your rank, then Mark Time. When the drum major signals Forward March, step off at a full step.

Other Members of the File

B-28. If you are not the first person in the file, turn left two steps after the person in front of you turns. Turn where the first file member turns. March forward until you are aligned with your rank, then Mark Time. When the drum major signals Forward March, step off at a full step.

BAND COMMANDER

B-29. Turn left two steps after the person to your left turns. March forward until you are aligned with the first rank, then Mark Time. When the drum major signals Forward March, step off at a full step.

BAND SERGEANT MAJOR/FIRST SERGEANT

B-30. When the drum major raises his arm in preparation for signaling a Left Turn, take one step forward with your left foot, rock back on your right foot, and step forward with your left foot. This will put you in line with the second rank. Continue to march in this position until the drum major gives the signal of execution. Mark Time one step after the signal of execution. Pivot to the left on the ball of your right foot two steps after the person on the left flank of the front rank pivots. This will return you to your original position two steps to the left of and in line with the front rank. March forward two steps for each rank in the band, minus two steps, then Mark Time. When the drum major signals Forward March, step off at a full step.

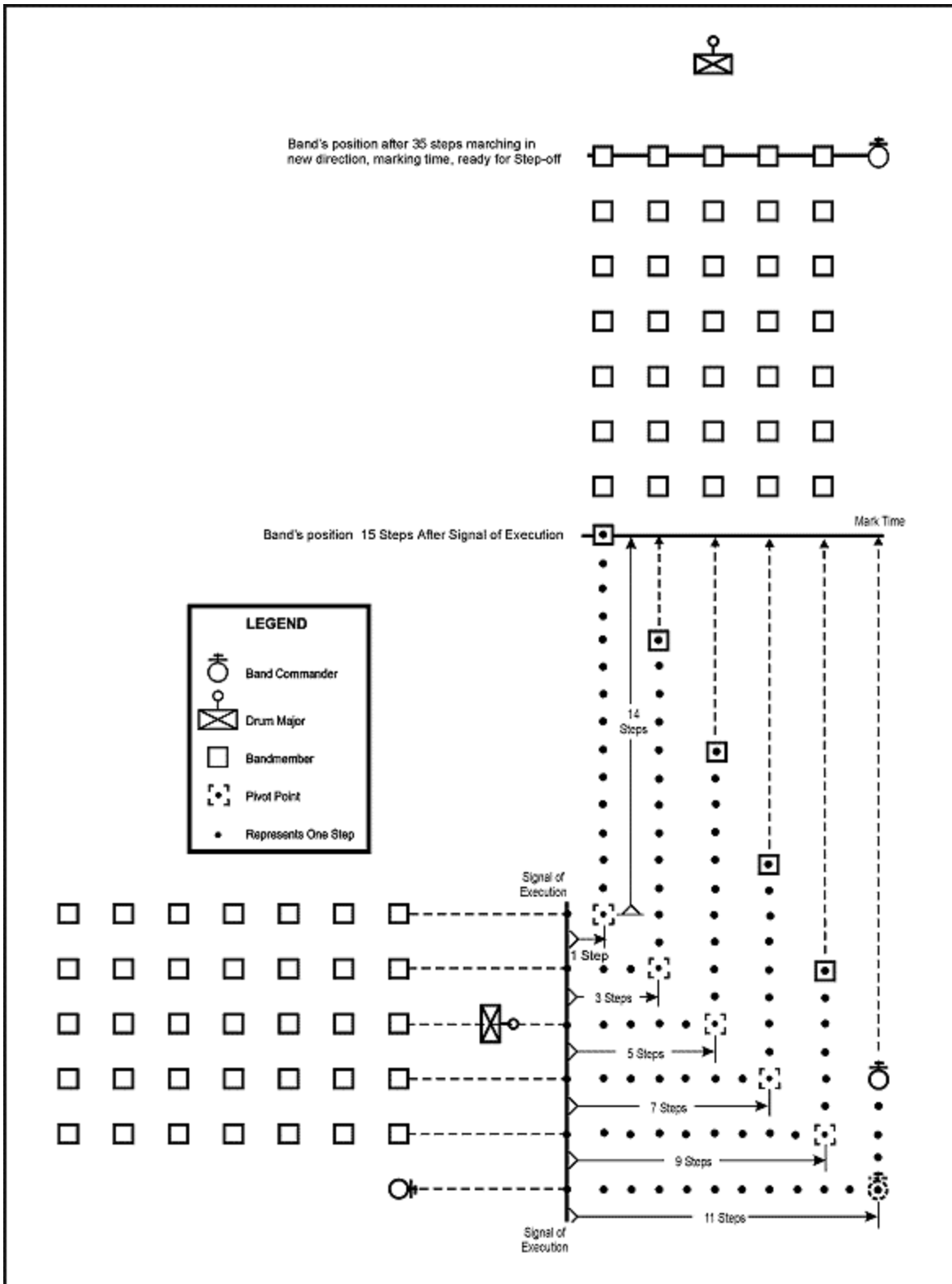

Figure B-5. Left Turn

RIGHT TURN

B-31. [Figure B-6](#) illustrates the procedures for the band to execute a Right Turn.

DRUM MAJOR

B-32. Perform the Right Turn as it is described in the Manual of the Mace. When the first band member in the right file reaches the place to turn, perform the preparatory signal, followed by the signal of execution. March forward until you are even with the first band member in the right file, then continue forward the appropriate number of steps and Mark Time. When all band members have turned and aligned themselves, signal a Forward March.

RIGHT FILE

First Person in the File

B-33. If you are the first person in the file, take the following actions when the drum major performs the signal of execution. Take one step and turn right. March forward two steps for each rank in the band, then Mark Time. When the drum major signals Forward March, step off at a full step.

Other Members of the File

B-34. If you are not the first person in the file, turn right two steps after the person in front of you turns. Turn where the first file member turns. March forward two steps for each rank in the band, minus two steps for each rank in front of you. For example, if you are in the fifth rank of a band with seven ranks, march forward six steps (14 minus 8). Mark Time. When the drum major signals Forward March, step off at a full step.

OTHER FILES

First Person in the File

B-35. If you are the first person in the file, take the following actions. Turn right two steps after the person to your right turns. March forward until you are aligned with your rank, then Mark Time. When the drum major signals Forward March, step off at a full step.

Other Members of the File

B-36. If you are not the first person in the file, turn right two steps after the person in front of you turns. March forward until you are aligned with your rank, then Mark Time. When the drum major signals Forward March, step off at a full step.

BAND COMMANDER

B-37. When the drum major raises his arm in preparation for signaling a Right Turn, take one step forward with your left foot, rock back on your right foot, and step forward again on your left foot. This will put you in line with the second rank. Continue to march in this position until the drum major gives the signal of execution. Mark Time one step after the signal of execution. Two steps after the person on the right flank of the front rank pivots, pivot to the right on the ball of your left foot. This will return you to your original position two steps to the right of and in line with the front rank.

BAND SERGEANT MAJOR/FIRST SERGEANT

B-38. Turn right two steps after the person to your right turns. March forward until you are aligned with the first rank, then Mark Time. When the drum major signals Forward March, step off at a full step.

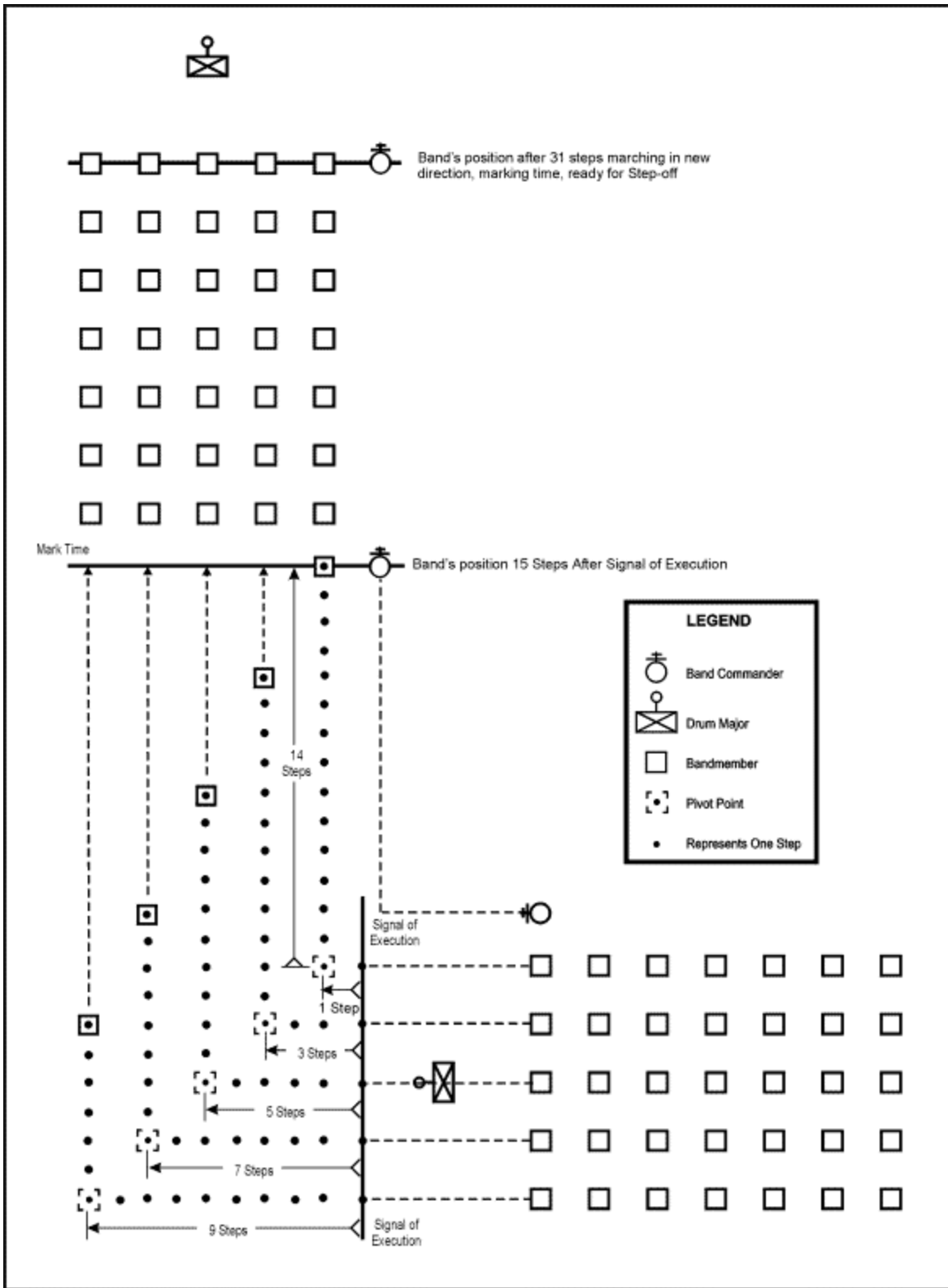

Figure B-6. Right Turn

LEFT TURN - ALTERNATE

DRUM MAJOR

B-39. Signal a Left Turn. (The signal for the alternate left turn is the same as that for the primary left turn.) Pivot to the left on the step after the signal of execution. March forward until you are the appropriate number of steps past the first person in the left file. The appropriate number of steps equals the number of files, minus one. For example, for a five-person front, continue four steps past the first person in the left file; for a four-person front, continue three steps past the first person in the left file. Mark Time until the front rank is on line in the new direction of march. Step off with a full step.

BAND COMMANDER

B-40. Continue to march in your position two steps to the right of the first person in the band's right flank file. Pivot to the left two steps after the first soldier in the right flank file pivots to the left. Continue to march at a full step in the new direction.

BAND SERGEANT MAJOR/FIRST SERGEANT

B-41. When the drum major raises his arm in preparation for signaling a Left Turn, take one step forward with your left foot, rock back on your right foot, and step forward with your left foot. This will put you in line with the second rank. Continue to march in this position until the drum major gives the signal of execution. Mark Time one step after the signal of execution. Pivot to the left on the ball of your right foot two steps after the person on the left flank of the front rank pivots. This will return you to your original position two steps to the left of and in line with the front rank.

LEFT FILE

First Person in the File

B-42. If you are the first person in the file, stop on your right foot one step after the signal of execution. Bring your left foot even with your right foot and begin to Mark Time. Continue to Mark Time until the person to your right pivots to the left. Two steps after the person to your right pivots, pivot to the left on the ball of your right foot. Continue to march at a full step in the new direction. Dress is to the right until the entire rank completes the turn. When the entire band has completed the turn, the dress reverts to the guide file.

Other Members of the File

B-43. If you are not the first person in the left file, stop on your right

foot one step after the signal of execution. Bring your left foot even with your right foot and begin to Mark Time. Continue to Mark Time until the file to your right steps off. Two steps after the file to your right steps off, step off at a full step. Pivot to the left on the ball of your right foot two steps after the person in front of you pivots. Continue to march at a full step in the new direction. Dress is to the right until the entire rank completes the turn. When the entire band has completed the turn, the dress reverts to the guide file.

RIGHT FILE

First Person in the File

B-44. If you are the first person in the file continue to march at a full step on the signal of execution. Two steps after the file to your left stops and begins to Mark Time, pivot to the left on the ball of your right foot. Continue to march at a full step in the new direction. The right file is the guide file until the entire rank has completed the turn. At that time the guide reverts to the center.

Other Members of the File

B-45. If you are not the first person in the right file, continue to march forward at a full step after the signal of execution. Two steps after the person in front of you turns, pivot to the left on the ball of your right foot. Continue to march at a full step in the new direction. Your file is the guide file until your entire rank has completed the turn. At that time the guide reverts to the center.

OTHER FILES

First Person in the File

B-46. If you are the first person in the file, stop on your right foot two steps after the file to your left stops and begins to mark time. Bring your left foot even with your right foot and begin to Mark Time. Continue to Mark Time while the person to your right turns. Two steps after the person to your right turns, pivot to the left on the ball of your right foot. Continue to march at a full step in the new direction. The right file is the guide file from the signal of execution until your entire rank has completed the turn. At that time, the guide reverts to the center.

Other Members of the File

B-47. If you are not the first person in the other files, stop on your right foot two steps after the file to your left stops and begins to Mark Time. Bring your left foot even with your right foot and begin to Mark Time.

Continue to Mark Time while the file to your right steps off. Step off at a full step two steps after the file to your right steps off. Two steps after the person in front of you turns, pivot to the left on the ball of your right foot. Continue to march at a full step in the new direction. The right file is the guide file from the signal of execution until your entire rank has completed the turn. When your rank has completed the turn, the guide reverts to the center.

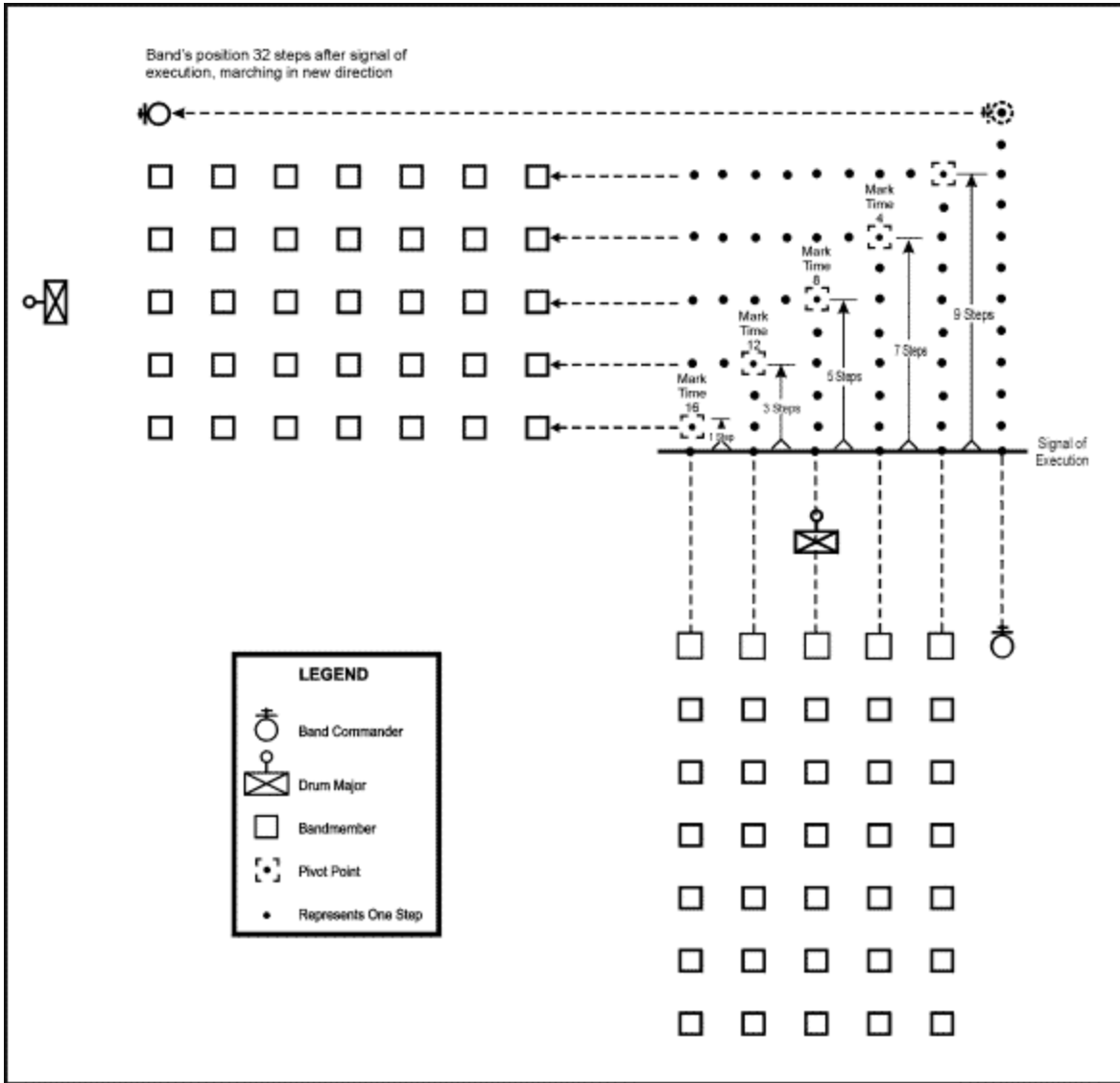

Figure B-7. Left Turn - Alternate

RIGHT TURN - ALTERNATE

DRUM MAJOR

B-48. Signal a Right Turn. The signal for the alternate right turn is the same as that for the primary right turn. Pivot to the right on the step after the signal of execution. March forward until you are the appropriate number of steps past the first person in the right file. The appropriate number of steps equals the number of files minus one. For example, for a five-person front, continue four steps past the first person in the right file; for a four-person front, continue three steps past the first person in the right file. Mark Time until the front rank is on line in the new direction of march. Step off with a full step.

BAND SERGEANT MAJOR/FIRST SERGEANT

B-49. Continue to march in your position two steps to the left of the first person in the band's left flank file. Pivot to the right two steps after the first soldier in the left flank file pivots to the right. Continue to march at a full step in the new direction.

BAND COMMANDER

B-50. When the drum major raises his arm in preparation for signaling a Right Turn, take one step forward with your left foot, rock back on your right foot, and step forward again on your left foot. This will put you in line with the second rank. Continue to march in this position until the drum major gives the signal of execution. Mark Time one step after the signal of execution. Two steps after the person on the right flank of the front rank pivots, pivot to the right on the ball of your left foot. This will return you to your original position two steps to the right of and in line with the front rank.

RIGHT FILE

First Person in the File

B-51. If you are the first person in the file, stop on your left foot one step after the signal of execution. Bring your right foot even with your left foot and begin to Mark Time. Continue to Mark Time until the person to your left pivots to the right. Two steps after the person to your left pivots, pivot to the right on the ball of your left foot. Continue to march at a full step in the new direction. Dress is to the left until the entire rank completes the turn. At that point the guide reverts to the center file, or to the right of center in a band with an even number of files.

Other Members of the File

B-52. If you are not the first person in the file, stop on your left foot one step after the signal of execution. Bring your right foot even with your left foot and begin to Mark Time. Continue to Mark Time until the file to your left steps off. Two steps after the file to your left steps

off, step off at a full step. Two steps after the person in front of you pivots, pivot to the right on the ball of your left foot. Continue to march at a full step in the new direction. The left flank file is the guide file until your entire rank completes the turn. At that time the guide reverts to the center file (or to the right of center in a band with an even number of files).

LEFT FILE

First Person in the File

B-53. If you are the first person in the file, continue to march at a full step on the signal of execution. Two steps after the file to your right stops and begins to Mark Time, pivot to the right on the ball of your left foot. Continue to march at a full step in the new direction. Your file is the guide file until the entire rank has completed the turn. At that time the guide reverts to the center file.

Other Members of the File

B-54. If you are not the first person in the file, continue to march forward at a full step after the signal of execution. Two steps after the person in front of you turns, pivot to the right on the ball of your left foot. Continue to march at a full step in the new direction. Your file is the guide file until your entire rank has completed the turn. At that time, the guide reverts to the center file.

OTHER FILES

First Person in the File

B-55. If you are the first person in the file, stop on your left foot two steps after the file to your right stops and begins to Mark Time. Bring your right foot even with your left foot and begin to Mark Time. Continue to Mark Time while the person to your left turns. Two steps after the person to your left turns, pivot to the right on the ball of your left foot. Continue to march at a full step in the new direction. The left file is the guide file from the signal of execution until the entire rank has completed the turn. At that time, the guide reverts to the center file.

Other Members of the File

B-56. If you are not the first person in the file, stop on your left foot two steps after the file to your right stops and begins to Mark Time. Bring your right foot even with your left foot and begin to Mark Time. Continue to Mark Time while the file to your left steps off. Step off at a full step two steps after the file to your left steps off. Two steps after the person in front of you turns, pivot to the right on the ball of your

left foot. Continue to march at a full step in the new direction. The left file is the guide file from the signal of execution until the entire rank has completed the turn. At that time, the guide reverts to the center file.

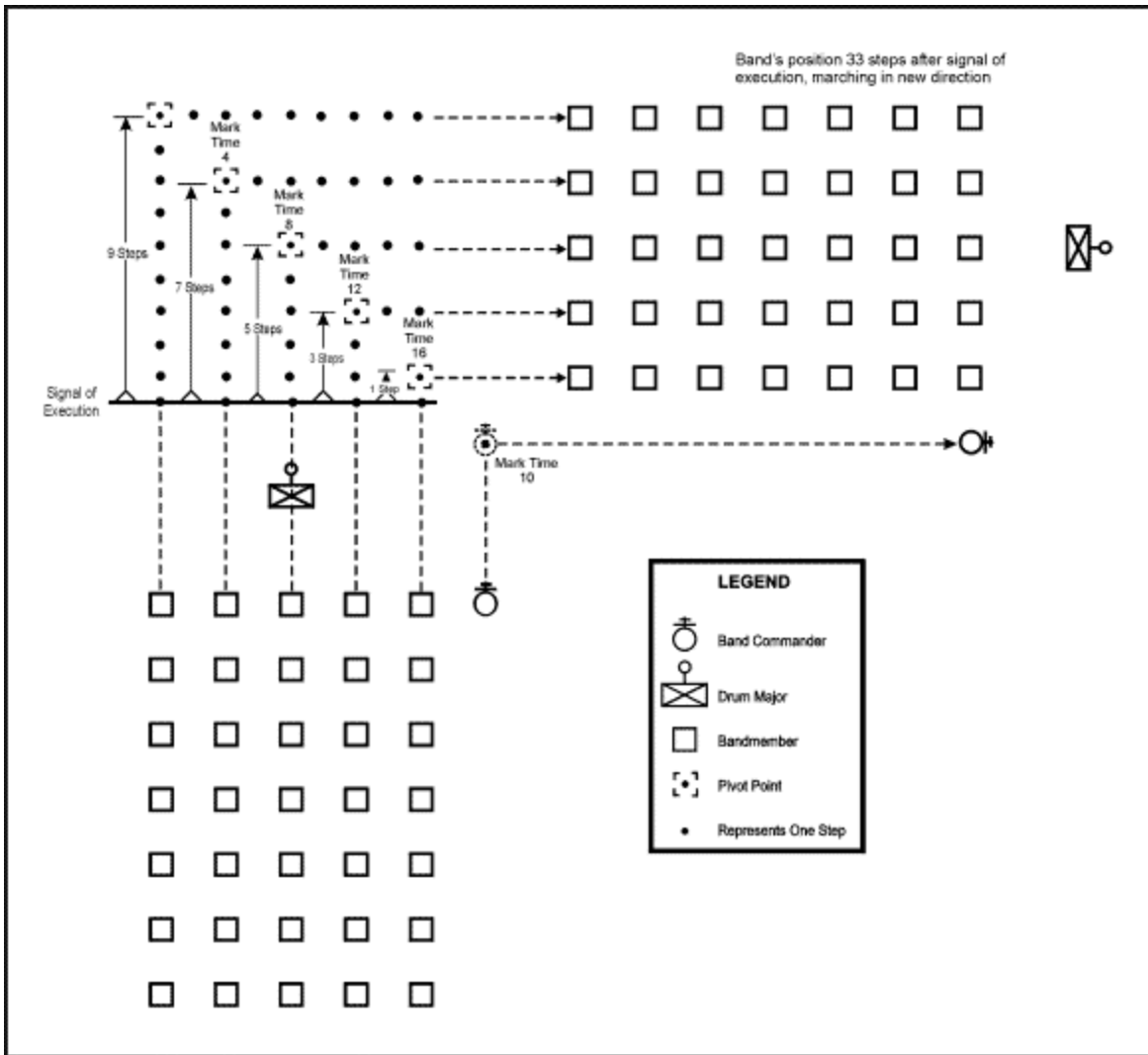

Figure B-8. Right Turn - Alternate

REVERSIBLE COUNTERMARCH

DRUM MAJOR

B-57. Give the preparatory signal. Give the signal of execution. When the entire band has completed the Countermarch, the drum major signals Forward March.

ALL OTHER BAND MEMBERS AND THE BAND COMMANDER

Front Rank

B-58. If you are in the front rank, when the drum major gives the signal of execution take one more fifteen inch step and do two consecutive fifteen inch Left Flanks. Continue to march at a half-step. (Trombone players will bring their instruments to the Ready Instruments position on the pivot of the first left flank. On the step after completing the second left flank, trombone players return to the Prepare To Play position. Both actions occur on the right foot.)

Other Ranks

B-59. If you are not in the front rank, when the drum major gives the signal of execution, immediately take up the half step. Turn on the fifth step after the person in front of you turns. Turn where the first rank turns. Guide on the center file of the band. In a band that has an even number of files, guide on the right center file.

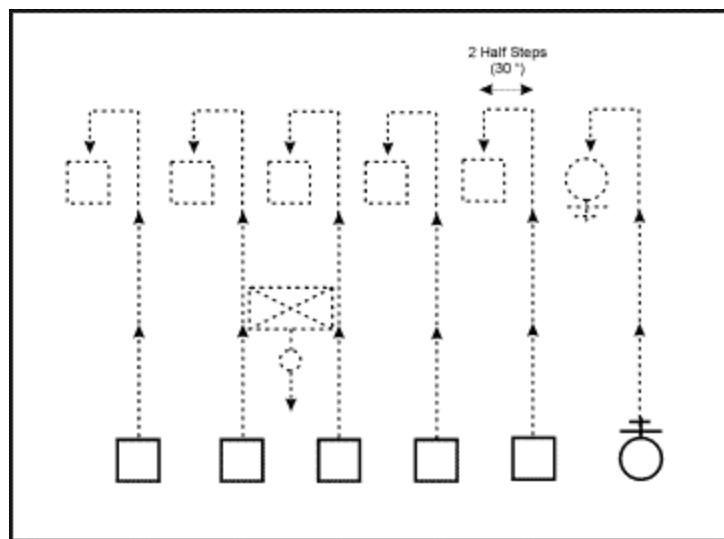

Figure B-9. Reversible Countermarch

NONREVERSIBLE COUNTERMARCH

DRUM MAJOR

B-60. Give the preparatory signal. If the band has an odd number of files, take one 30-inch step to the left. Mark Time until the first rank comes on line with you. March with the first rank until you reach the place to turn. Give the signal of execution. Reverse your direction by rocking back on your right foot and pivoting to the right. Complete the

reverse by pivoting on your next left step. Continue marching at a full step until you pass the last rank. If the band has an even number of files, take one 30-inch step to the right. After the first rank completes the turn, signal them to Half Step. When the entire band has completed the turn, signal Forward March.

BAND COMMANDER

B-61. On the signal of execution, follow the file beside you in a semicircle to the left. When you are aligned with the front rank, Mark Time. When the drum major signals Forward March, step off at a full step.

GUIDE FILE

B-62. When the drum major gives the signal of execution, march at a half step. If you are the first person in the guide file, follow the drum major in a semicircle to the left (both in bands with an even number of files and those with an odd number of files). If you are not the first person in the guide file, follow the person in front of you. Begin to Mark Time on the drum major's signal. When the drum major signals Forward March, step off at a full step.

FILES TO THE RIGHT OF THE GUIDE FILE

B-63. On the signal of execution, continue marching at a full step. If you are the first person in your file, march in a semicircle to the left. If you are not the first person in your file, follow the person in front of you. When you are aligned with the guide in your rank, begin to Mark Time. When the drum major signals Forward March, step off at a full step.

FILES TO THE LEFT OF THE GUIDE FILE

B-64. On the signal of execution, continue marching at a full step. If you are the first person in the file, march in a semicircle to the right. If you are not the first person in your file, follow the person in front of you. When you are aligned with the guide in your rank, begin to Mark Time. When the drum major signals Forward March, step off at a full step.

BAND SERGEANT MAJOR/FIRST SERGEANT

B-65. On the signal of execution, march in a semicircle to the right. March to the inside of the bandmaster. When you are aligned with the first rank, begin to Mark Time.

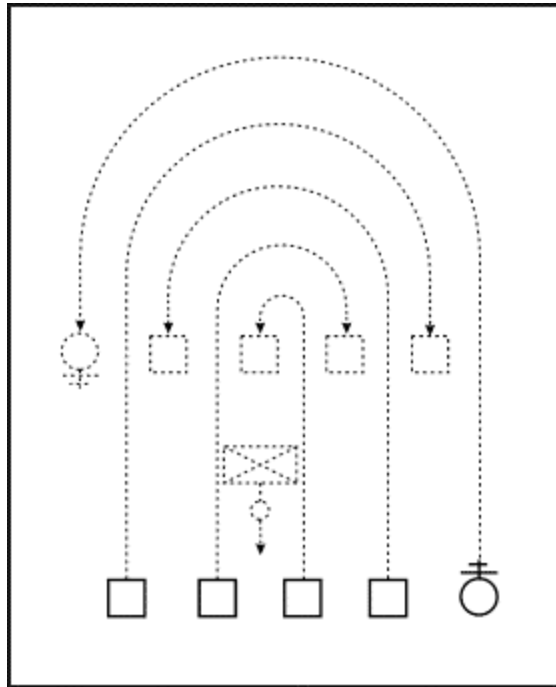

Figure B-10. Nonreversible Countermarch - Even Number of Files

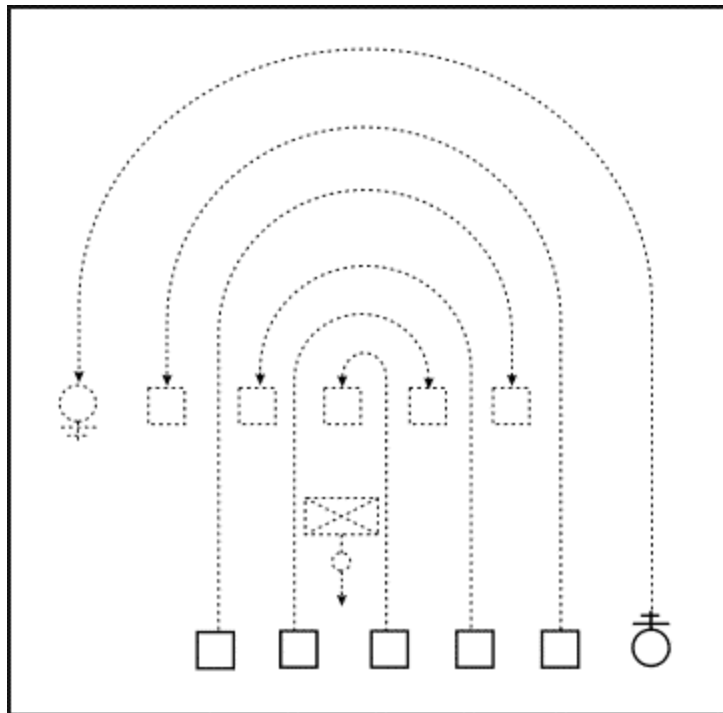

Figure B-11. Non-reversible Countermarch - Odd Number of Files

GUIDE AROUNDS AND HALF TURNS

DRUM MAJOR

B-66. Raise your right arm to guide the band to the right. Raise your left arm to guide the band to the left. Your arm should extend horizontally outward from your side at shoulder height. Your palm should face forward. Assume the new direction of march. Keep your arm in position until the entire band has assumed the new direction of march. Adjust length of steps as necessary. Drop your arm. No Forward March signal is necessary. The guide file will maintain the appropriate distance behind you.

GUIDE FILE

First Person in the File

B-67. If you are the first person in the file, pivot on the ball of the lead foot in the direction indicated when the drum major raises his arm. March at a half step until all members of your rank have assumed the new direction of march. Resume marching at a full step.

Other Members of the File

B-68. If you are not the first person in the file, shorten or lengthen your steps as necessary to pivot at the approximate point that the lead person pivots. March at a half step until all members of your rank have assumed the new direction of march. Continue marching at a full step.

OTHER FILES

First Person in the File

B-69. If you are the first person in the file, pivot on the ball of the lead foot in the commanded direction when the drum major raises his arm. Shorten or lengthen your steps to stay dressed on the guide file. When your rank has assumed the new direction of march, continue marching at a full step.

Other Members of the File

B-70. If you are not the first person in the file, begin turning at the approximate point that the lead person pivoted. Shorten or lengthen your steps as necessary to stay dressed on the guide file. When your entire rank has assumed the new direction of march, resume marching at a full step.

BAND COMMANDER/BAND SERGEANT MAJOR/FIRST SERGEANT

B-71. If you are on the outside of the turn, lengthen your steps to stay dressed on the guide file. When your rank has assumed the new direction of march, continue marching at a full step. If you are on the inside of the turn, pivot on the ball of the lead foot when the drum

major raises his arm. March at a half step until all members of your rank have assumed the new direction of march. Resume marching at a full step.

CHANGING MUSIC

B-72. The band commander or drum major directs "Change your music", while the band is at parade rest. If this is not possible, bring the instruments up, allowing enough time for the band members to change their music before giving the downbeat. Bandmembers will change their music with a minimum of motion.

OBSTACLES

B-73. When guiding around an obstacle, the lead person in the file makes the movements necessary to get around the obstacle. All other file members follow the person in front of them.